

BRAVAT TRIO COMMERCIAL MOTION SENSOR FAUCETS LIGHT OIL RUBBED BRONZE FINISH SPECS

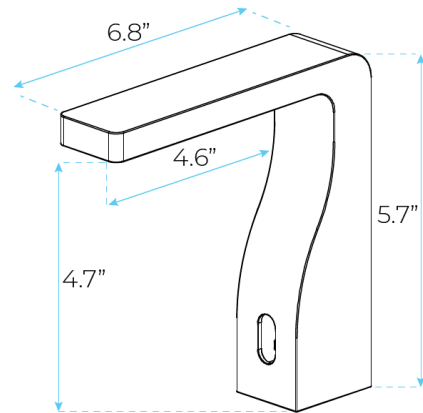

Specs:

- Power: DC:6V(4AA alkaline battery)
- AC:220V-240V; 50/60HZ
- Detection Zone: 16-32 cm or adjustable
- Battery lifespan: 100000 cycles
- Static Power Consumption: 0.36mw
- Working Power consumption: 0.5mw
- Inductive Opening Time: < 1 second
- Inductive Closing Time: < 2 second
- Flow rate at 3 Bar Flow pressure for basin:12 L/min
- Flow pressure: min. 0.5 bar - recommended 1 – 5 bar
- Operating pressure: max. 10 bar
- Test pressure: 16 bar

